



BDAV History

Building Designers
Association Victoria

Produced June 2004

The success of the Building Designers Association of Victoria today is due, largely, to the solid foundations put into place by the Association's Founding Members and, in particular, the various Past Presidents of the Association. Much of the content of this section has been contributed by many of the Past Presidents, in order to preserve the historical information and knowledge gained over the years. The BDAV thanks all contributors for the material contained herein. In particular, we wish to acknowledge the contribution by Mr Brian Huntley who has provided much valuable, historical, information.

BDAV Presidents

The various Presidents of the BDAV, over the years, have been:

Bruce Pittard	President 1983 - 1984
Rob Parker (deceased)	
Ronald Pickford	President 1984 - 1987
Graeme Hewitt	President 1987 - 1989
Kevin Slater	President 1989 - 1991
David Cooke	President 1991 - 1993
Robert McLauchlan	President 1993 - 1997
Sean Hamilton	President 1997 - 1999
Tony Iseppi	President 1999 - 2001
Geoffrey Hoare	President 2001 - 2004

BDAV – The Beginning

contribution by Brian S Huntley

BDAV Member Number 16; joined March 1983

In the latter part of the 1970s and early 1980s, I had a number of discussions with a man by the name of Rob Parker who ran a drafting service at Woodend. The discussions centred around the formation of a Building Designers Association similar to that which existed in South Australia.

At the time I had been running BSH Drafting in Bundoora since September 1969, and Rob hounded me until he convinced me that an industry body was essential for our industry, as we were all doing our own thing, with no cohesion and/or lobbying ability to protect our interests.

At that time I was a member of HIA, so I had access to industry information, etc, but of course their main interest was builders not draftsmen.

As a result of Rob's efforts and successful lobbying... and I cannot remember exactly how it came about, due to the passage of time... a meeting was called under the auspices of the Victorian Chamber of Manufacturers at Industry House, St Kilda Road, Melbourne, for the 24th November 1982. [See Appendix A for invitation to attend.]

This meeting was attended by some 38 draftsmen/women, together with representatives of the VCM and the HIA, Mr D Slade from VCM chaired the meeting.

Three industry members addressed the meeting: Mr Joe Ammerlaan spoke on Copyright problems; Mr Mario Rapinett spoke on ethical standards within the industry; and Mr Rob Parker spoke on problems with building regulations, particularly in country areas.

The Chairman then pointed out that these were only a few of the problem areas that an industry association could take up on behalf of its members.

Following general questions, the meeting unanimously agreed that an association should be formed, and a steering committee elected. The following 12 people agreed to serve on the steering committee:

Roger Daniel RV Daniel Holdings Pty Ltd
John Gannon..... Gannon Chrisfield & Associates
Rob Parker..... Woodend Drafting Co
Joe Ammerlaan Australian Drafting Service
Mario Rapinett..... Duo Day Drafting
Anthony Clouston Skilled Engineering
Judy Alexander..... J Alexander Design and Drafting
Peter Onofretchook Sun Crest Home Planning
Brian Huntley BSH Drafting
Rod Gallagher Institute of Draftsmen of Australia
Bruce Pittard Eltham Design & Drafting Services
John Carroll..... Able Drafting Service

It was agreed that the steering committee would elect its own Chairman at its first meeting which would be held on Thursday, 9th December 1982 commencing at 7pm, and it would report to a general meeting to be held in February 1983. [Refer Appendix B for copy of the minutes of the exploratory meeting held 24/11/1982.]

Building Designers
Association of Victoria
PO Box 174
Carlton South VIC 3053
ABN: 36 982 485 577

www.bdav.org.au

Phone: (03) 9416 0227
Fax: (03) 9416 0115
Email: info@bdav.org.au

The first meeting of the steering committee was held in Room 1 at the Victorian Chamber of Manufacturers rooms on Thursday, 9th December 1982 and, at this meeting, Mr John Gannon was duly elected Chairman of the steering committee. [See *Appendix C for meeting agenda and Appendix D for minutes of the meeting.*]

Issues dealt with at the meeting included:

- Eligibility for membership – qualifications and membership classifications;
- Ethics and responsibility;
- Membership fee structure;
- Constitution: a sub-committee was formed to look at a constitution;
- Affiliation/liaison with other professional bodies;
- Representation with Standards Association of Australia and other relevant organisations;
- Contractual documentation;
- Group buying power;
- Legal advice and representation.

A date was then set for another meeting of the Steering Committee on Thursday, 10th February 1983.

At this meeting a Draft Constitution was presented by the sub-committee and it was moved by Mr R Parker and seconded by Mr R Daniel and agreed, "That the Draft Constitution including amendments made at this meeting be adopted".

The second important motion made at this meeting was to adopt a name for the Association. It was moved by Mr B Huntley and seconded by Mr M Rapinett and agreed, "That the name 'Building Designers' Association of Victoria' be adopted".

It was also agreed that, because HIA had formed a group with similar aims and objectives to ours and had a membership in excess of 30, that the General Meeting called for the 24th February 1983 should be deferred until the 10th March 1983, to allow an assessment of the ramifications that the formation of this other group may have on our intentions. [Refer *Appendix E for minutes of 10th February 1983.*]

An invitation was subsequently sent to all attendees of the Exploratory meeting to attend the Inaugural General Meeting of the Building Designers Association of Victoria, to be held at Industry House Melbourne, on Thursday 10th March 1983 at 7pm. [See *Appendix F.*]

At this meeting Mr John Gannon, Chairman of the Steering Committee welcomed everyone and acted as Chairman for the meeting.

Mr Gannon gave a brief summary of the Steering Committee's activities and was supported by the following committee members: Messrs B Pittard, M Rapinett and R Daniel. The Chairman then advised of a resolution made by the Steering Committee that membership would be confined to Building Designers, as they had their own particular problems.

Fees were then discussed, and it was agreed that a fee of \$50.00 should be charged for the remainder of 1982/83 and that \$100.00 should be charged for the 1983/84 year. With no joining fee.

The clauses relating to membership in the Constitution were read and it was moved by Mr M Trompf and seconded by Mr R Daniel and agreed, "That all present be formally invited to join the Association and, on receipt of fees, be accepted as members."

It was then moved by Mr Gannon and seconded by Mr Daniel, "That Mr Bruce Pittard be elected President of the Association." There being no other nominations, Mr Pittard was duly elected.

As there were no members of the Association at this stage, the election of a committee was held over until the next general meeting.

After discussion on finances it was moved by Mr Trompf and seconded by Mr Ammerlaan and agreed, "That the membership fee for the current year, ie, until 30th June 1983 be \$50.00 per member.

The meeting closed at 9.20pm and the date for the next meeting was set for Thursday, 14th April 1983, commencing at 6.00pm. [Refer *Appendix G for the agenda and minutes of the Inaugural Meeting.*]

At the General Meeting held on the 14th April 1983, Ms Judy Alexander, Mr Bruce Pickford and Mr Malcolm Trompf were elected to the Executive Committee. [Refer *Appendix H for minutes of 14th April 1983.*]

I have also included a copy of our first newsletter dated May 1983 [Refer *Appendix I*]; it was very basic, and a copy of the notice of our first Annual General Meeting held 30th June 1983 [Refer *Appendix J*].

B Huntley

June 1984	Newsletter	20 March 1986	General Meeting
26 July 1984	General Meeting	17 April 1986	Informal Meeting – Keith Cloughton, GM of Croydon, Guest Speaker.
August 1984	Newsletter	29 May 1986	General Meeting
13 Sept 1984	General Meeting	26 June 1986	Fourth Annual Meeting held at MBAV. 20 Attended & Secretary (P. Maddox) Election of Office bearers 1986/97: President R Pickford Vice President G Hewitt Treasurer/Immediate Past President B Pittard Executive Committee R Watts, K Slater & M Trompf
22 Oct 1984	Standard Agreement form prepared by Solicitors.	31 July 1986	General Meeting
25 Oct 1984	General Meeting	18 Sept 1986	General Meeting
18 Nov 1984	"Picnic at Hanging Rock" – Social Family Function	27 Nov 1986	General Meeting
6 Dec 1984	Annual Dinner held at Village Green Motor/Hotel Glen Waverley	Nov 1986	Notice of Motion to amend Rule 34 of Constitution re Insignia forwarded to members.
21 Feb 1985	General Meeting	12 Dec 1986	Christmas Function – Sovereign Hill Music Hall
18 April 1985	General Meeting	5 Feb 1987	General Meeting
20 June 1985	Third Annual General Meeting held at MBAV. 14 attended and Secretary (P. Maddox) Election of Office bearers 1985/86: President R Pickford Vice President M Rapinett (Treasurer) Immediate Past President B. Pittard Executive Committee R Daniel & I McIntosh Membership Committee R Daniel/B Gallagher	26 March 1987	General Meeting
25 July 1985	General Meeting. M Rapinett resigns as member of Executive.	30 April 1987	Informal Meeting – Guest Speaker BDASA President.
19 Sept 1985	General Meeting. R. Lyne appointed to Executive Committee to replace M. Rapinett. B.Pittard to take over Treasurer's role previously carried out by M. Rapinett.	28 May 1987	General Meeting
18 Nov 1985	Incorporation of Association. Documentation received from Ellison Hewitt and Whitehead Solicitors.	30 July 1987	Fifth Annual General Meeting held at Sir Robert Peel Hotel. 19 attended & Secretary (P. Maddox) Election of Office Bearers 1987/88: President G Hewitt Vice President K Slater Treasurer B Pittard Executive Committee R Lyne, M Trompf & J Alexopolous P Maddox resigned as Secretary. Denise Slater to act as Secretary.
28 Nov 1985	General Meeting	15 Oct 1987	General Meeting
18 Dec 1985	Christmas Social Function – Picnic at Hanging Rock	27 Nov 1987	Christmas Function
11 Dec 1985	Annual dinner at Squires Cellar Restaurant – Glen Waverley	10 Mar 1988	General Meeting – approval for scholarship awards
11 March 1986	Incorporation of Association	12 May 1988	General Meeting

14 July 1988	Sixth Annual General Meeting – held at Royal Oak Hotel, Richmond. 18 attended plus 2 Guests. Election of Office bearers 1988/89: President G Hewitt Vice President K Slater Treasurer B Pittard Immediate Past President R Pickford Executive Committee R Lyne, M Trompf	13 June 1991	General Meeting
13 Oct 1988	General Meeting	8 Aug 1991	Ninth Annual General Meeting held at Clunies Ross House. 18 attended. Election of Office bearers 1991/92: President D Cooke Vice President R Daniel Immediate Past President K Slater Treasurer B Pittard Executive Committee R Watts, F Masten & R McLauchlan
Dec 1988	Christmas Social Function – Bendigo	17 Oct 1991	General Meeting
20 April 1989	General Meeting at “Studleys on the Yarra”	15 Dec 1991	Christmas Function – BBQ at Pound Bend, Warrandyte
11 May 1989	General Meeting	20 Feb 1992	General Meeting
18 May 1989	Factory Tour Pilkington ACI, Greens Road, Dandenong	21 May 1992	General Meeting
20 July 1989	Seventh Annual General Meeting held at Smith Street Bar & Bistro. 13 attended. Election of Office bearers 1989/90: President K Slater Vice President No nominations Treasurer B Pittard Executive Committee R. Pickford, D. Cooke & R. Lyne	20 Aug 1992	Tenth Annual General Meeting held at Clunies Ross House. 18 attended. Election of Office bearers 1992/93: President D Cooke Vice President R McLauchlan Immediate Past President K Slater Treasurer B Pittard Executive Committee M Trompf, F Masten & R Watts
14 Sept 1989	Informal Social Dinner	28 Nov 1992	Christmas Function – Social indoor Tennis, Wheelers Hill
19 Oct 1989	General Meeting	11 Feb 1993	General Meeting
Dec 1989	Christmas Function – Chinese Restaurant, Ballarat	13 May 1993	General Meeting
8 March 1990	General Meeting – Clunies Ross House	26 Aug 1993	11th Annual General Meeting held at Clunies Ross House. 25 attended. Election of Office bearers 1993/94: President R McLauchlan Vice President D Cooke Immediate Past President D Cooke Treasurer F Masten Executive Committee M Trompf, R Watts & S Hamilton
10 May 1990	General Meeting	11 Nov 1993	General Meeting
19 July 1990	Eighth Annual General Meeting held at Clunies Ross House. 18 attended. Election of Office bearers 1990/91: President K Slater Vice President D Cooke Immediate Past President G Hewitt Treasurer B Pittard Executive Committee R Watts, R Daniel & F Masten. R Pickford suggested history of the Association should be recorded.	27 Nov 1993	Christmas Function – Social Indoor Tennis, Wheelers Hill.
12 Dec 1990	General Meeting	10 Feb 1994	General Meeting
14 Feb 1991	General Meeting	24 May 1994	General Meeting
18 April 1991	General Meeting	25 Aug 1994	12th Annual General Meeting

APPENDIX A

Victorian Chamber of Manufactures

Industry House
370 St Kilda Road
Melbourne VIC 3004
GPO Box 1469N
Melbourne VIC 3001
Telex: 325 96 VICMAN
Telephone: (03) 6984111

11th November 1982

BSH Drafting
98 Gleeson Drive
BUNDOORA 3083

Dear Sir

The Victorian Chamber of Manufactures (VCM) has been requested by representatives of the drafting services industry to host a meeting of the Industry at Industry House on Wednesday, 24th November 1982, at 6.30 pm.

The objective of the evening will be to appoint a Steering Committee, to examine the feasibility of establishing a body, to represent the interests of independent drafting services and report back at a later date. The provisional name selected for the organisation is 'The Association of Independent Drafting Services'.

Some initial matters which should be addressed by the Steering Committee include:

- A constitution for the body
- Ethical standards and quality of service
- Relationships with Local Government
- Registration of drafting services
- Clarification of Uniform Building Regulations
- Copyright and Legal representation

The meeting arrangements are detailed on the reply slip enclosed. I will be the host for this mutual meeting and look forward to your company.

Please complete the reply slip, enclose your registration fee of \$10, and return them to this office by Friday, 19th November 1982 to confirm your place at this most important function. Queries should be referred to me on telephone (03) 698 4317.

Thank you for your attention.

Yours sincerely
Darryl I Slade
Manager Industry Services

Victorian Chamber of Manufactures

Industry House
370 St Kilda Road
Melbourne VIC 3004
GPO Box 1469N
Melbourne VIC 3001
Telex: 325 96 VICMAN
Telephone: (03) 6984111

NOTICE OF MEETING

ASSOCIATION OF INDEPENDENT DRAFTING SERVICES (A.I.D.S.)

▪ THE DATE:

Wednesday, 24th November 1982

▪ THE PLACE:

The Norman Jones Auditorium, Mezzanine Floor, Industry House, 370 St Kilda Road, Melbourne, 3004

▪ THE PROGRAMME:

Registration	6.30 p.m.
Refreshments	6.30 – 7.00 p.m.
Meeting	7.00 – 9.00 p.m.
Depart	9.00 p.m.

▪ CAR PARKING:

Car Parking is available on the Lower Ground Floor, Industry House (enter from St Kilda Road, down the ramp on the right hand side of the building).

▪ REGISTRATION FEE:

A registration fee of \$10 per person is required.

APPENDIX B

Victorian Chamber of Manufactures
Industry House
370 St Kilda Road
Melbourne VIC 3004
GPO Box 1469N
Melbourne VIC 3001
Telex: 325 96 VICMAN
Telephone: (03) 6984111

ASSOCIATION OF INDEPENDENT DRAFTSMEN

MINUTES OF EXPLORATORY MEETING HELD AT INDUSTRY HOUSE,
370 ST KILDA ROAD, MELBOURNE, AT 7.00PM ON WEDNESDAY, 24TH NOVEMBER 1982

PRESENT

Messrs D J Slade (Chairman) VCM
R J Parker Woodend Drafting
J T Daly J T Daly Drafting
J W Ammerlaan Australian Drafting Service
P Onofretchook Sun Crescent Home Planning
T A Scott Castlemaine Design/Draft
A Clouston Skilled Engineering
R Gallagher Institute of Draftsmen Aust
J Banhidy Camberwell Drafting Services
B Gallagher T B Gallagher & Co Pty Ltd
B Fagg Bruce Fagg & Co
B Calestani B Calestani Home Planning &
Drafting Service
A Sanders Durran Drafting
B Huntley BSH Drafting
D Murray DJM Design Construction Pty Ltd
T Norton A Stirling & Associates
R Bibby Ayule Planning & Design
G Sharp EMC Design
R R Long Plan Printing & Drafting Pty Ltd
L C Taig BSP (A/Asia) Pty Ltd
G Keyte G K Design Pty Ltd
Ms J Alexander J Alexander Design & Drafting
K G Slater K G Slater Design & Drafting Service
R Pickford R & J Pickford Design Drafting
G Hewitt G D & N E Hewitt Pty Ltd
M Warren Warren Drafting Service Pty Ltd
J Carroll Able Drafting Service
I Cochrane Faradale Drafting
J Gannon Gannon Chrisfield & Assoc
R Lyne Eastern Suburbs Drafting Service
M Mowat Epping Drafting Service Pty Ltd
Ms W Barron Berwick Drafting & Design Services
E Barron Berwick Drafting & Design Services
R Daniel R V Daniel Holdings Pty Ltd
P Shaw Paul Shaw & Assoc Pty Ltd
B Pittard Eltham Design & Drafting Services
H Fleming Hesk Enterprises Pty Ltd
G J Rubython Robocom A/Asia Pty Ltd
G Aldous Housing Industry Association
M Rapinett Duo Day Drafting
C L Wilson (Secretary) VCM

INTRODUCTION

The Chairman welcomed everyone to the meeting on behalf of the Director of the VCM, Mr Brian Powell. The structure and operation of the VCM were briefly outlined to those present with particular reference being made to the Industry Services Division, which as the name implies, provides a service to Associations and Sections of industry. He explained that currently we were servicing approximately 90 Associations and were well qualified to service a group such as the one proposed by Drafting Services.

AIM OF MEETING

The aim of this particular meeting was to promote the formation of a body to represent the views and the interests of the independent drafting and design industry in Victoria and in particular to elect a Steering Committee, which would be a temporary device to get the Association up and running and then it is expected it would be disbanded in favour of an Executive Committee.

The Association would require a Constitution, a Code of Ethics, Procedures for Regulating and Governing the Body, etc, an indication of the problems to which the group could address itself.

The meeting was addressed by three people from the industry:

1. Mr Joe Ammerlaan, Australian Drafting Service, who detailed problems relating to copyright.
2. Mr Mario Rapinett, Duo Day Drafting – involved in new home design, explained the problems relating to ethical standards within the industry.
3. Mr Rod Parker, Woodend Drafting, addressed himself to the problems of building regulations, particularly in country areas.

It was pointed out to the Chairman that the three items to which the gentlemen had addressed themselves were only three of many areas which could be taken up by an Association on behalf of members.

APPENDIX B (continued)

Questions were asked relating to the specific subjects mentioned by the speakers, which were indicative of the subject matter, which could be discussed at Association meetings.

Mr Grant Aldous of the Housing Industry Association wished those present every success in setting up the Association at the same stating they were aware of the problems in the industry and had convened a meeting to discuss these problems scheduled for Monday, 29th November.

With regard to the operation of the Association, the Chairman advised that the Steering Committee would consider every aspect and the thought was that it should be as widely based as possible with a very strong voice. The VCM had traditionally represented small business and was very interested in getting this organisation off the ground.

FEE STRUCTURE & SECRETARIAT

The fee structure for joining the Association was raised and it was considered that this was a subject for discussion at the Steering Committee meeting for recommendation to be made. The VCM would supply the Secretariat for the Association and appropriate fee for that service would be charged. No charges would be made until the Association was operating.

OTHER ASSOCIATIONS

Reference was made to the Drafting Contractors' Association, working under the auspices of MTIA, and to the Building Designers' Association of South Australia. The President of the Drafting Contractors' Association offered assistance to the new Association. Mr R. Gallagher, Promotions Officer – Institute of Draftsmen Australia, stated that they were presently altering the structure of the organisation, which had 2,400 members and qualification requirements for membership. This group produced a bi-monthly newsletter and a journal and would be pleased to assist.

Reference was made to an affiliated body in Western Australia called 'The Private Practising Contracting Draftsmen', which is listed as a separate group in the Yellow Pages. The Federal Council was pushing strongly to have a similar group set up in Victoria. This was being investigated. A figure of over 100,000 practising draftsmen working throughout Australia was mentioned.

QUALIFICATIONS

The majority of those present indicated that they did not have any formal qualifications and it was pointed out that this Association was being set up to cover this type of person. One of the aims of the Association would be to try and improve the qualifications of the membership and most people entering the industry were currently doing so as a result of TAFE courses and hence were qualified.

Following general questions the meeting unanimously agreed that an Association should be formed and that the meeting should proceed with the formation of a Steering Committee. The following 12 members agreed to act at the Steering Committee:

Roger Daniel R V Daniel Mouldings Pty Ltd
John Gannon Gannon Chrisfield & Assoc
Rob Parker Woodend Drafting Co
Joe Ammerlaan Australian Drafting Service
Mario Rapinett Duo Day Drafting
Anthony Clouston Skilled Engineering
Judy Alexander J Alexander Design & Drafting
Peter Onofretchook Sun Crescent Home Planning
Brian Huntley BSH Drafting
Rod Gallagher Institute of Draftsmen Australia
Bruce Pittard Eltham Design & Drafting Services
John Carroll Able Drafting Service

The Committee was considered to be representative of the members and this Committee would elect its own Chairman at the first meeting, which would be held on Thursday, 9th December 1982, commencing at 7.00pm and to report to a general meeting to be convened in February. An Agenda would be prepared for the 9th December meeting and all members of the Steering Committee were asked to contribute Agenda items to Mr Colin Wilson as soon as possible.

The meeting closed at 8.45pm.

CONFIRMED:

Chairman: _____

Date: _____

CLW:JW
30/11/1982

APPENDIX C

Victorian Chamber of Manufactures

Industry House
370 St Kilda Road
Melbourne VIC 3004
GPO Box 1469N
Melbourne VIC 3001
Telex: 325 96 VICMAN
Telephone: (03) 6984111

ASSOCIATION OF INDEPENDENT DRAFTSMEN

1st December 1982

TO: MEMBERS OF STEERING COMMITTEE

NOTICE OF MEETING OF THE STEERING COMMITTEE OF "THE ASSOCIATION OF INDEPENDENT DRAFTSMEN"
TO BE HELD AT THE VICTORIAN CHAMBER OF MANUFACTURES, ROOM 1, 370 ST KIDA ROAD, MELBOURNE,
ON THURSDAY, 9TH DECEMBER 1982 COMMENCING AT 7.00PM

AGENDA

1. Election of Chairman
2. Eligibility for Membership
 - Qualifications
 - Membership Classification
3. Ethics & Responsibility
4. Fee Structure
5. Constitution
 - Formation of Sub-Committee
6. Affiliation/Liaison with other Professional Bodies, eg. Institute of Draftsmen
7. Representation with SAA and other Organisations
8. Contractual Documentation (Standard Form)
9. Group Buying Power (Consideration of Benefits)
10. Legal Advice & Representation
11. General Business

Colin L. Wilson
Senior Executive Officer

Car Parking: Parking is available on the Lower Ground Floor, Industry House, entrance from St Kilda Road down ramp.

Members are requested to be on time, as the Agenda is lengthy and as much business as possible should be completed in the available time.

If you are unable to attend, please contact Colin Wilson, on 698 4353.

APPENDIX D

ASSOCIATION OF INDEPENDENT DRAFTING SERVICES

MINUTES OF MEETING OF THE STEERING COMMITTEE HELD AT INDUSTRY HOUSE,
370 ST KILDA ROAD, MELBOURNE, ON THURSDAY, 9TH DECEMBER 1982

PRESENT

Messrs B Huntley BSH Drafting
V Ammerlaan Australian Drafting
M Rapinett Duo Day Drafting
Ms J Alexander J Alexander Design & Drafting
R Parker Woodend Drafting
J Carroll Able Drafting Services
R Gallagher Institute of Draftsmen Australia
B Pittard Eltham Design & Drafting Services
R Daniel R V Daniel Holdings Pty Ltd
J Gannon Gannon Chrisfield & Assoc
C Wilson VCM

APOLOGY

Mr A Clouston Skilled Engineering

INTRODUCTION

Mr C Wilson, Executive Officer, VCM, occupied the Chair and recapitulated on the meeting held on 24th November 1982, the Minutes of which had been distributed to all members of the Steering Committee. Mr Wilson further explained VCM's position regarding the formation of the Association and what the VCM could do to assist. An Agenda had been prepared for this meeting, but the majority of the items were not expected to be covered, however, it was necessary to establish those areas of expertise which it was intended that this Association should cover. Having established this, a Constitution would need to be prepared to cover the operations of the new group.

The meeting agreed that before a Chairman of the Steering Committee could be elected, it would be necessary to establish who could and who could not be members of the group. It was considered to be most important that from the outset and before the business of the meeting could proceed, the eligibility 'be established'.

A lengthy discussion ensued with every member of the Committee participating. The majority of members agreed that the Association should be confined to draftsmen associated with the building industry. Although there were several dissenting members, it was agreed that the meeting should proceed on this basis.

At this point of the meeting several members indicated that they would not be able to serve on the Committee. Mr Carroll withdrew and Mr Gallagher, who indicated that he would not be able to serve on the Committee, offered continuing help to get Association off the ground. Both members were thanked for their assistance thus far.

ELECTION OF CHAIRMAN

Members agreed that the meeting could now proceed with the election of the Chairman for the Steering Committee and Mr John Gannon of Gannon Chrisfield & Associates was duly elected and occupied the Chair for the remainder of the meeting.

AGENDA ITEMS

The Chairman referred to the Agenda and considered that the majority of items on the Agenda were not items that could be dealt with by the Steering Committee but would be subjects to be dealt with by the Association after it had been formed.

FEE STRUCTURE

This had been mentioned earlier in the meeting and Mr Wilson advised the meeting that for a group of this nature meeting perhaps on a bi-monthly basis, a fee of between \$3,000 and \$4,000 could be considered as a minimum. This is totally related to the amount of work required.

CONSTITUTION

The Chairman considered that the first and most essential requirement from the Steering Committee was to prepare a Constitution and a sub-committee should be formed to do this work. The following members were elected:

Messrs R Daniel
R Parker
J Ammerlaan
J Gannon (Chairman ex-officio)

The Secretary agreed to send to each of these members copies of Constitutions for other Associations, which could be used as a basis for the preparation of the Constitution for this group.

It was agreed that a draft copy should be prepared before the end of this year and that it should be presented to a meeting of the Steering Committee scheduled for Thursday, 3rd February 1983. The next meeting of potential members of the group would be Thursday, 17th February 1983, at a time to be decided.

CONFIRMED:

Chairman: _____

Date: _____

CLW:JW
13/12/1982

Victorian Chamber of Manufactures
Industry House
370 St Kilda Road
Melbourne VIC 3004
GPO Box 1469N
Melbourne VIC 3001
Telex: 325 96 VICMAN
Telephone: (03) 6984111

BUILDING DESIGNERS' ASSOCIATION OF VICTORIA

25th February 1983

Dear Sir

You are aware that a meeting of representatives from the drafting industry, held at the VCM on 9th December 1982, supported the formation of an Association to look after the interests of the industry and elected a Steering Committee to prepare the groundwork for the commencement of such an Association.

Since that time the Steering Committee has met on two occasions and a Constitution has been prepared, which will require acceptance at an early date.

The meeting scheduled for 10th March 1983 is the Inaugural Meeting, where you will elect your Officers, approve the Constitution and carry on with business according to the Agenda prepared by the Steering Committee.

The future of the Association is up to you – it needs your support by your attendance and input to the meetings.

We are looking forward to a good attendance at this meeting and have endeavoured to contact as many as possible through the means available. If you know anyone who may be interested and who has not received an invitation, bring them along!

Yours faithfully

John Gannon
Chairman/Steering Committee

Attach. Agenda

:JW

BUILDING DESIGNERS' ASSOCIATION OF VICTORIA

25th February, 1983

TO: MEMBERS OF STEERING COMMITTEE

AGENDA FOR THE INAUGURAL GENERAL MEETING OF THE
BUILDING DESIGNERS' ASSOCIATION OF VICTORIA
TO BE HELD AT INDUSTRY HOUSE, 370 ST KILDA ROAD, MELBOURNE,
ON THURSDAY, 10TH MARCH 1983, AT 7.00P.M.

1. Opening and Welcome
2. Apologies
3. Statement of Objectives
4. Election of Chairman
5. Adoption of Constitution
6. General Business

NOTE: Please advise Mr Colin Wilson, VCM, of your intended attendance on 698 4353
no later than Tuesday, 8th March.

:JW

APPENDIX G (part 2)

BUILDING DESIGNERS' ASSOCIATION OF VICTORIA

MINUTES OF INAUGURAL MEETING OF THE BUILDING DESIGNERS' ASSOCIATION OF VICTORIA
HELD AT INDUSTRY HOUSE, 370 ST KILDA ROAD, MELBOURNE, ON THURSDAY, 10TH MARCH 1983, 7.00 PM

PRESENT

Messrs	J Gannon (Chairman) Gannon Chrisfield & Associates
Ms	J Alexander J Alexander, Design & Drafting
	A Hubbard St Albans Drafting Service Pty Ltd
	M Rapinett Duo Day Drafting
	J Ammerlaan Australian Drafting Service
	B Gallagher T B Gallagher & Co Pty Ltd
	B Huntley BSH Drafting
	R Daniel R V Daniel Holdings Pty Ltd
	R Pickford R & J Pickford Design Drafting
	R Watts R L Watts Design
	G Wain Geoff Wain Building Design Consultant
	B Pittard Eltham Design & Drafting Services
	M Trompf Skyline Design Pty Ltd
	R L Robitschek AADE & Pallerdale Pty Ltd
	D Crumpton Balwyn Design & Drafting
	T Martin Balwyn Design & Drafting
	B Sinclair Mont-Eltham Drafting
	L Gave Tullamarine Drafting
	R Pethorick Tullamarine Drafting
	N Downie Calder Drafting Service
	P Shaw Paul Shaw & Assoc Pty Ltd
	K Slater K G Slater Design & Drafting Service
	G Outhred Mooroolbark Design
	B Bingham Contract Drafting Services Pty Ltd
	R Parker Woodend Drafting Co
	C L Wilson (Secretary) VCM

APOLOGIES

Messrs	M Mallat
	T Hynes Hoban Hynes
Mrs	B Weaver Forest Hill Design Drafting
	B Van Huizen Van Huizen Planning & Drafting P/L
	R B Lambert R B Lambert Drafting Services
	D Seymour Seydign Drafting Pty Ltd
	G D Hewitt G D & N E Hewitt Pty Ltd

INTRODUCTION

Mr John Gannon of Gannon Chrisfield and Associates, Chairman of the Steering Committee, welcomed everyone to this meeting and expressed some disappointment at the lack of numbers. He reviewed the activities of the Steering Committee, which had met on a number of occasions since the previous general meeting of the industry and had resolved a number of points as well as prepare the groundwork for the Association to be set up. The work included preparation of a Constitution and resolving the objectives. He went on to say that there was a great need for co-operation of people within the industry in spite of the aggressive competition, and there was also a need for a greater flow of information within the industry.

It was expected that a regular newsletter would be prepared and the industry would have its own insignia, which would be recognised by the community at large. This would be prepared in due course.

The following members of the Steering Committee supported the remarks made by the Chairman:

- Mr B Pittard, Eltham Design & Drafting Services
- Mr M Rapinett, Duo Day Drafting
- Mr R Daniel, R V Daniel Holdings Pty Ltd

Following a question, the Chairman advised the meeting of a resolution made by the Steering Committee that membership would be confined to the building designers, as they had their own peculiar problems, although at the same time it was recognised that this would be restrictive on membership.

The Chairman considered that the numbers attending this meeting would be insufficient to form and maintain the Association. The group had progressed a long way since its inception and considerable interest shown throughout the industry, not only by the people

present but others who were not present had indicated they would be interested in joining.

A fee of \$50 for the remainder of 1982/83 was discussed and for the full year 1983/84 a figure of \$100 was thought to be about the right amount depending on membership. No joining fee would be charged. The 1983/84 fee would be finally set at the Annual General Meeting in July.

The meeting agreed that on the basis of the interest shown to date and the potential to increase the membership to the required figure, which was considered to be a minimum of 60, the Association should proceed.

The clauses relating to membership in the Constitution were read to the meeting and following this, it was moved by Mr Trompf, seconded by Mr Daniel and agreed –

“That all present be formally invited to join the Association and on receipt of fees be accepted as members.”

ELECTION OF PRESIDENT

It was moved by Mr. Gannon, seconded by Mr. Daniel –

“That Mr Bruce Pittard be elected President of the Association.”

There being no further nominations, Mr. Pittard was elected unanimously.

As there were no members of the Association at this stage, the election of an Executive Committee would be an item on the Agenda for the next meeting.

CONSTITUTION

The proposed Constitution, prepared by the Steering Committee, was read to the meeting and following discussion on several points, which would need clarification in the future, it was moved by Mr Parker, seconded by Mr Trompf and agreed –

“That the Constitution as read to the meeting be accepted.”

FINANCE

The Secretary pointed out that there was difficulty in assessing secretarial fees for the Association, because no real indication had been given on the amount of work that VCM would be required to do. Based on the activities of similar Associations and the anticipation that the Association would meet on a monthly basis, this would require about ten per cent of the Secretary's time plus the back-up services supplied by the VCM, the fee for the full twelve months, i.e commencing July 1983, would be \$5,000 p.a.

The Secretary went on to say that in consideration of the need to increase the membership substantially, the fees for the remainder of this financial year would be at a reduced level of \$3,000 p.a. commencing from 1st April, 1983, i.e for three months at a figure of \$275 per month. The figure of \$5,000 was based on ten per cent of Secretary's time including all back-up services such as Executive Officer's Secretary, meeting rooms, keeping accounts, etc. It was also pointed out that all incidental costs in the running of the Association would be charged accordingly and these included such items as postage, photocopying, trunk calls, etc.

Following discussion, it was moved by Mr Trompf, seconded by Mr Ammerlaan and agreed –

“That the membership fee for the current year, i.e until 30th June 1983, be \$50 per member.”

NEXT MEETING DATE

The next meeting of the Association will be held on Thursday, 14th April, 1983, commencing at 6.30 p.m.

CLOSURE

The meeting closed at 9.20 p.m.

APPENDIX H

BUILDING DESIGNERS' ASSOCIATION OF VICTORIA

MINUTES OF GENERAL MEETING OF THE BUILDING DESIGNERS' ASSOCIATION OF VICTORIA HELD AT INDUSTRY HOUSE, 370 ST. KILDA ROAD, MELBOURNE, ON THURSDAY, 14TH APRIL 1983, COMMENCING 6.30 P.M.

PRESENT

Messrs Bruce Pittard (Chairman) Eltham Design & Drafting Services
Rod Parker R Parker Building Design & Drafting
Ron Pickford R & J Pickford Design Drafting
Geoff Wain Geoff Wain Building & Design Consultant
Ray Watts R Watts Design
Barry Sinclair Mont-Eltham Drafting
Ms Judith Alexander J Alexander Design & Drafting
Paul Shaw Paul Shaw & Associates Pty Ltd
Bert van Huizen .. Van Huizen Planning & Drafting Pty Ltd
Malcolm Trompf Skyline Design
Mario Rapinett Duo Day Drafting
Ms Suzanne Kairuz Kairuz Interior to Exterior Design
Joe Ammerlaan Australian Drafting Service
Colin L Wilson (Secretary) VCM

APOLOGIES

Messrs Brian Huntley BSH Drafting
Roger Daniel R V Daniel Holdings Pty Ltd
G Hewitt G D & N E Hewitt Pty Ltd
Brian Douglas
John Daly J T Daly Drafting
T B Gallagher T B Gallagher & Co
Gary Sharp Sharp Design
T Scott Castlemaine Design & Drafting
A Hubbard St Albans Drafting

CONFIRMATION OF MINUTES OF PREVIOUS MEETING

It was moved by Mr Sinclair, seconded by Mr Pickford, and agreed –

“That the Minutes of the Inaugural Meeting held on 10th March 1983, were a correct record of the proceedings of that meeting.”

MEMBERSHIP

The Chairman expressed concern and disappointment at the lack of numbers attending the meeting. Numbers were down on the previous meeting and this had occurred in spite of the acceptance by those present at that meeting that there were others in the industry who were interested in joining. To keep the Association afloat for the remainder of this financial year, it was considered that an additional ten (10) members would be required. The total membership to date (18) had each paid a membership fee of \$50.

There was a consensus among members that the Association would keep going at least until the money ran out but a major effort would need to be mounted to increase the membership. It was felt that the meetings must be made attractive for people to participate and this could include guest speakers from organisations such as the UBR and insurance companies. Also there was an immediate need for the specific benefits offered by the Association to be spelt out very clearly.

ELECTION OF EXECUTIVE COUNCIL

The following nominations had been received for election to the Executive Council:

Ms J Alexander J Alexander Design
Mr R Pickford R & J Pickford Design & Drafting
Mr M Trompf Skyline Design

It was moved by Mr Parker, seconded by Mr Wain and agreed unanimously –

“That Ms Alexander and Messrs Pickford and Trompf be accepted as members of the Executive Council.”

As no nomination was received for the position of Vice President, the election to this office was left in abeyance until the next general meeting.

SUB-COMMITTEES

1. Recruiting of New Members: It was felt that rather than having a special sub-committee all attending members could assist in a recruitment campaign. Members tendered names of various companies that they would contact and a personal approach would be made to those who were present at the previous meeting and indicated that they would be joining the Association but were not present at this meeting nor had as yet paid their membership fees. It was felt that a personal approach could have immediate effects, as many contacts had already been made.
2. Newsletter: Ms Alexander agreed to act as the co-ordinator for the preparation of the newsletter and Mr Parker offered his assistance. All members were asked to forward any items of interest to Ms Alexander for inclusion in the newsletter, which would then be printed and distributed with the Minutes of this meeting.
3. Press Release: Mr Rapinett agreed to prepare and be responsible for a press release on the Association.
4. Publicity: It was felt that as much publicity as possible should be given to the Association and its activities and the following suggestions were made, where an article could appear:
 - Local newspapers
 - Institute of Building Surveyors
 - Institution of Engineers
 - The Leader Group
 - Various journals circulated throughout the industry

It was felt that many papers would welcome publicity on the Association.

FINANCE

The Secretary tabled a statement of receipts and payments for the period to 31st March 1983, which showed a credit balance of \$597.96 and included subscriptions amounting to \$750.00.

The meeting ratified the expenditure of \$152.04, being for postage, photocopying and printing/stationery. These expenses had mainly been incurred in the general mailing to the industry prior to the inaugural meeting.

MEMBERSHIP FEES

Following discussion, it was moved by Mr Parker, seconded by Mr Pickford and agreed –

“That all new members would pay a membership fee of \$100.00 and that this amount would cover fees until 1st July 1984.”

INSIGNIA

It was agreed that as many members as possible would submit a suggested insignia for the Association to adopt. It was considered that we should have an insignia and letterhead for the Association as soon as possible for use by members.

DATE OF NEXT MEETING

The next general meeting of the Association will be held on Thursday, 26th May 1983, commencing at 6.30 p.m.

APPENDIX I

NEWSLETTER

BUILDING DESIGNERS ASSOCIATION OF VICTORIA

No. 1

May 1983

- Editorial
- Presidents Message.
- Insurance.
- Self Employment
- Logo Design

PRESIDENT: Bruce Pittard

Welcome to the first newsletter of the "Building Designers Association of Victoria."

A regular newsletter format has not yet been established, but with the excitement and enthusiasm stemming from establishing the Association, this newsletter is of an interim format to share the excitement, report progress, discuss topics of common interest and notify members of future events.

This Association is no different to any other new Association just starting out in that the task ahead of it appears daunting, but with help, active participation and contributions by its members, it will achieve its aims and objectives.

As one of Australia's past colourful politicians once put it, "An Association doesn't have a body to kick or a soul to damn", no-one can physically hurt or curse the Association, but members can harvest its rewards successfully if they actively fertilize it with their active participation.

Do you have INDEMNITY INSURANCE?

Do you work from your home and does your INSURANCE COVER give the protection you need?

Do you recognise your LEGAL RESPONSIBILITIES?

Do you understand fully, COPYRIGHT laws?

Do you have access to correct LEGAL ADVICE?

These are some of the many areas the Association plans to research, resolve and advise its members on. The Association welcomes your membership and assistance in helping to resolve common problems and achieving its aims and objectives.

Next General Meeting of the Association will be held on Thursday, 26th May 1983 at Industry House, 370 St Kilda Road, Melbourne, commencing at 6.30 P.M.

PRESIDENTS MESSAGE

I wish to welcome all members, and prospective new members into the newly formed Building Designers Association of Victoria.

This Association has come into being by the initial efforts of Messrs Rob Parker, Mario Rapinett and Joe Ammerlaan who, as owners of Building Design and Drafting Services recognised how the formation of such an Association would be of considerable help to self employed members within the industry.

As was shown by all persons connected with the formation of this Association there is a genuine need within our industry for close co-operation and a greater cross flow of information which would be to the benefit of all members.

The basic aim of the Association is to establish a recognised and responsible body of Building Designers and Draftspersons whose professional standard of work and business ethics will be acceptable by both public and government bodies.

Some of the areas that the Association will direct its efforts to in the immediate future include close liaison with the Building Surveyors Association, formulation of a guideline to setting fees and charges, delineation of areas of responsibility and investigation into the areas of Copyright and legal responsibility. It is hoped that Professional Indemnity and general insurances especially tailored to suit our industry's individual needs would be offered to members at highly competitive rates.

The list of benefits which would become available to us as an established group, rather than individuals, is unending, and that is why it is in each members own interest to help promote the Association.

The success of this Association is entirely dependent upon the number of members it can attract and to the input each member can contribute.

In conclusion, I would like to wish the Association every success for its growth and remind all members that the future of the BDAV is in your hands.

LOGO DESIGN

The Association needs a logo, or some form of identifying insignia, fitting the occupation of members. So members and prospective members, fancying themselves as clever logo designers (and those that don't fancy themselves) are invited to submit any number of designs at the next meeting. Sorry no prize, only the satisfaction of knowing you did it!

INSURANCES

At the last meeting the question of insurances was raised, covering two areas. Firstly the question of members who work from home. Generally, householders contents policies do not cover tools of trade, however one member was able to have his policy amended to include his equipment.

It would be interesting to hear from other members as to the cover they have.

The second area is that of professional indemnity insurance. At present to our knowledge no company will insure a person who is not a qualified Architect or Engineer. It would be interesting if anyone has found any company who will.

With the ever increasing legal actions that are coming in to all professions, it may be time to start some investigations into the possibilities of obtaining such insurances. The Association as a professional body may be able to convince an insurance company on behalf of its members.

Food for thought if enough members are interested.

SELF EMPLOYMENT

In a recent article published in the April edition of "Architect", an institute member has written in regards to Drafting Services and Building Designers operating their own businesses and feels that this practice should be eliminated and all Draftsmen and Draftswomen should be in their rightful places and work for the Architects or the Engineers, not themselves.

He concludes with the note that as the Institute of Architects now has two members within Parliament, action should be taken.

I don't need to go into the implications of this, however one member tells us that a similar action was tried in South Australia some time ago but was defeated because the Building Designers Association of South Australia (which has now been in operation for about 20 years), along with other affiliated associations was able to stop any action being taken.

This is an important subject and must be discussed by all members so that a policy can be formulated as to what procedures should be taken if the problem arises.

* * * *

ANNUAL GENERAL MEETING

TO MEMBERS OF THE BUILDING DESIGNERS ASSOCIATION

The next general meeting of the Building Designers Association is on Thursday the 30th June 1983, at 7pm, at Master Builders Association, 332 Albert Street, East Melbourne.
It is imperative that all members attend.

PRESENT EXECUTIVE COUNCIL

President	- Bruce Pittard	435-5083
Vice President	- Rob Parker	435-5460
Immediate Past President	- Malcolm Trompf	850-4465

EXECUTIVE COUNCIL

	- Ron Pickford	053-394030
	- Judy Alexander	735-5245
Secretary/Treasurer	- Mario Rapinett	729-9169

All positions will be vacated at the next meeting and nominations will be taken for all positions for the incoming Executive Council for 1983-1984.

Any person(s) interested in joining the Association may contact any of the above members or Garry Sharp 579-2829.

NOTE: MEMBERSHIP SUBSCRIPTIONS ARE DUE BY THE 30TH JULY 1983.

BUILDING DESIGNERS ASSOCIATION OF VICTORIA

NOTICE OF MEETING

The 1st Annual General Meeting of the Association will be held at the Ground Floor Committee Room, Master Builders Association, Albert Street, East Melbourne on Thursday 30th June 1983 commencing 7:00pm.

AGENDA

1. Opening and Welcome
2. Attendance/Apologies
3. Financial Report
4. All executive positions to be declared vacant and nominations accepted for office bearers for 1983-1984
5. Election of Office Bearers
 - (a) President
 - (b) Vice President
 - (c) Immediate Past President
 - (d) Executive Council – 2 Positions
6. General Business
7. Date of next meeting
8. Closure

BUILDING DESIGNERS ASSOCIATION OF VICTORIA

NOMINATION FORM
(Please Print)

To: The Secretary
Building Designers' Association of Victoria
GPO Box 1469N
MELBOURNE 3001

Name

Company

VICE PRESIDENT:

IMMEDIATE PAST PRESIDENT:

EXECUTIVE COUNCIL:
1.
2.
3.

I, of (Company)
do hereby nominate the above persons for the positions indicated and in so doing
CONFIRM THAT I HAVE ASCERTAINED THEIR WILLINGNESS TO STAND FOR THE POSITIONS HELD.

Signature: Date:

I, of (Company)
hereby second the nomination of the above persons for the positions indicated.

Signature: Date:

If elected, I agree to accept the office of for the year ending 1983.

Signature: Date:

BUILDING DESIGNERS' ASSOCIATION OF VICTORIA

MINUTES OF GENERAL MEETING OF THE BUILDING DESIGNERS' ASSOCIATION OF VICTORIA
HELD AT INDUSTRY HOUSE, 370 ST KILDA ROAD, MELBOURNE, ON THURSDAY, 26TH MAY 1983 COMMENCING AT 6.30 PM

PRESENT

Messrs Bruce Pittard (Chairman) . Eltham Design & Drafting Services
Ms Judy Alexander J Alexander Building Design & Drafting
Messrs Joe Ammerlaan Australian Drafting Service
John Ashley Whittlesea Drafting
Ray Bankier Bankier Services
John Daly J T Daly Drafting
Roger Daniel RV Daniel
John Gannon Gannon, Chrisfields & Associates
Brian Huntley BSH Drafting
Peter Hyndman . Building Advisory & Consultancy Services
Ms Suzanne Kairuz Kairuz Interior to Exterior Design
Messrs Bob Lyne Eastern Suburbs Drafting Service
John Martin John Martin & Associates
Rod Parker R Parker Building Design
Mario Rapinett Duo Day Drafting
Bill Reid W T Reid Drafting
Alan Rich Alan M Rich & Associates
Ray Watts R L Watts Design
Garry Sharp Sharp Design
Paul Shaw Paul Shaw & Associates
Barry Sinclair Mont-Eltham Drafting
Malcolm Trompf Skyline Design
Geoff Wain Geoff Wain Building Design Consultant
Tom Rose VCM
Colin Wilson VCM

APOLOGIES

Messrs David Cheong
Graham Hewitt G D & N E Hewitt Pty Ltd
Ron Pickford R & J Pickford Design Drafting
David Seymour Seydign Drafting Pty Ltd
Kevin Slater K G Slater Design & Drafting Services
Geoff Tanner

CONFIRMATION OF MINUTES OF PREVIOUS MEETING

It was moved by Mr Parker, seconded by Mr Wain and agreed –
"That the minutes of the General Meeting held on 14th April 1983 are a correct record of the proceedings of that meeting".

MATTERS ARISING

It was noted that the election of Executive Council was not in accordance with the Constitution and Rules of the Association in that three members were elected where as two only are required. This situation was rectified under Agenda Item 6, election to Fill Casual Vacancy.

MEMBERS GENERAL DISCUSSION

The chairman expressed concern regarding the future of the Association under the aegis of VCM. With 24 financial members presently and assuming a possible growth to 30 it was felt that it would be impossible to continue with the present agreement. To be a viable Association and to continue with VCM it was believed that a membership of at least 60 would be required.

An investigation had been undertaken as to alternatives and that preliminary figures had indicated the Association could operate with as few as 25 members. At this stage it was difficult to be accurate as to the finances required to operate the Association at another venue.

Consideration would be given to securing the services, on a part-time basis, of a person to act as Secretary. It was generally felt that a considerable amount of effort would yet be required to achieve the full potential of the Association.

It was moved by Mr Daniel, seconded by Mr Wain and agreed unanimously –

"That the Building Designers' Association of Victoria terminates its Association with VCM on the 31st May 1983".

It was moved by Mr. Trompf, seconded by Mr. Watts and agreed–

"That Mr Rapinett be appointed as Secretary/Treasurer of the Association until such time as more suitable arrangements could be made."

PROJECTION OF FUTURE COSTS AND ALTERNATIVES

Discussion on this matter was of a general nature and until some more definite plans were formulated no specific decisions were made.

ELECTION TO FILL CASUAL VACANCY

For (i) Vice President
(ii) Immediate Past President

The Chairman called for nominations for the vacant positions.

Mr R Parker was nominated as Vice President and Mr M Trompf was nominated as immediate past President There being no further nominations those nominees were duly elected.

SUB-COMMITTEE TO VET MEMBERSHIP APPLICATIONS

It was agreed that those appointed to the Sub-Committee should hold qualifications sufficient to satisfy the position and to ensure applicants of a fair appraisal. Mr Gannon and Mr Daniel had volunteered their services for this Committee and it was believed that Mr Gallagher (not present) would accept office should it be offered.

It was moved by Mr Trompf, seconded by Mr Lyne and agreed –

"That Mr Gannon and Mr Daniel be appointed and that Mr Gallagher be approached to accept appointment."

NEW MEMBERSHIP APPLICATION FORM

It was decided that the Membership Sub Committee should investigate the format of the application form and submit their recommendations for consideration.

LOGO DESIGN

Several designs were submitted, but due to time constraints these were circulated for consideration with the final decision to be made at a later date.

FINANCE

The Secretary reported to the meeting that the Association currently had a credit balance of \$453.33.

CORRESPONDENCE

Correspondence as tabled by the Secretary was circulated.

GENERAL BUSINESS

Discussions as to the future of the Association continued with the Executive Committee agreeing to meet to consider the matter. The next news letter would advise further details.

In an effort to increase membership, it was moved by Mr Daniel, seconded by Mr Trompf and agreed –

"That a Recruiting Sub-Committee be formed. Mr Sharp and Mr Parker volunteered their services and were duly appointed".

DATE OF NEXT MEETING

It was agreed that the next meeting would be held at 7.00 pm, 30th June 1983 at a venue to be fixed.

Having no further business the Chairman declared the meeting closed.

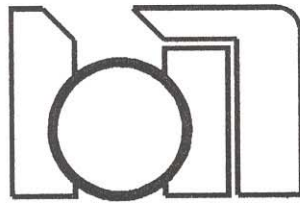

building designers
association
of australia ltd.

The drawing below shows the correct proportions
of the original State Logo used and Registered
by South Australia
Registered under Trade Marks Act 1955
Class No. 42 TM 410 439

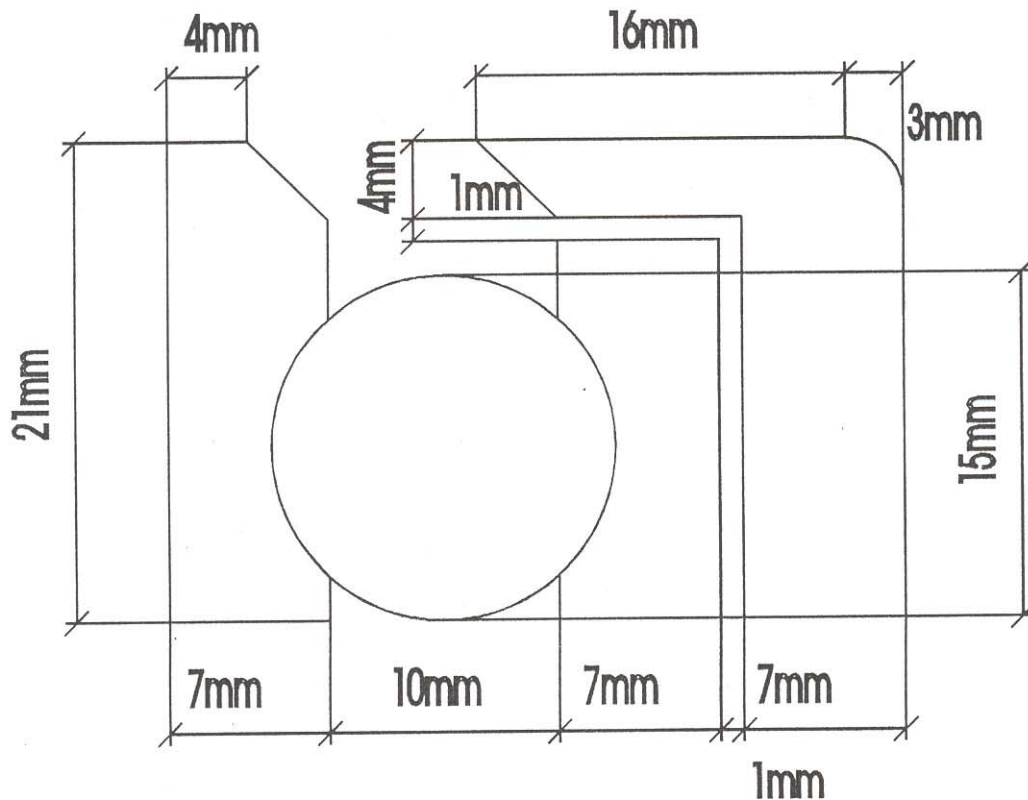

1987-1989

*contribution by Graeme Hewitt
BDAV Member Number 18; joined March 1983;
retired 2002. Granted Honorary Membership 2002*

One of my first tasks as President was an attempt to make contact with The Canadian Association of Professional Building Designers through an "Information Pamphlet" that came into the hands of the Association. Unfortunately, contact could not be made, in spite of several attempts by correspondence and by telephone whilst I was in Canada on holiday.

The structure of the Association continued to be in the format of Executive Committee meetings prior to ordinary general meetings; whereby the Committee considered all of the correspondence and the like, and reported on relevant matters to the general meeting – making recommendations where appropriate for general members to be informed, as part of the decision making. There was a continual struggle to get members to a meeting – even with that format – and interesting and varied guest speakers at the general session times.

Denise Slater took over the role of Association Secretary for a period, following the resignation of the previously appointed part-time secretary.

Meetings continued to be held in the Sir Robert Peel Hotel in Collingwood, although it was realised that that was far from an ideal proposition in the long term.

Considerable time and effort was put into the compilation of a "Terms of Engagement" document for use by Association members, incorporating a sample scale of fees as provided to us by the BDASA with whom we had previously established a good working co-operative relationship. I believe some minor difficulties were encountered in that alliance due to their relative long-term establishment compared to ours, and their overall membership numbers and relevant activities, but that certainly did not detract from their support and encouragement to this Association.

Considerable problems with the architects' organisation relative to the operations of "non architects" during which time a number of our members (self included) were the subject of threatening letters regarding the use of the term "Architect" and "Architectural". Interesting to note that South Australia had experienced the same problems some years before.

The formation of a "National Body" came on the scene in 1987, especially from South Australia because of their close liaison with us and attempts to break into the remaining states – Western Australia being in the early stages of development (I think).

I attended the AIBS Conference at Warragul representing the Association – at their invitation.

Incorporation of the Association was completed late in 1987 and the first information brochure published and distributed (5,000) that same year.

We became partners with South Australia in the provision of Professional Indemnity Insurance to our members, negotiating a "deal" with the South Australian Company on a bulk deal basis.

In 1988 Russell Andrews (one of our members) and his wife Valerie produced the first edition of "The Owner Builder Magazine". Russell duly resigned from the Association – in due course – to continue full time in the production of that periodical.

In March 1988 we entered into negotiations objecting to the scale of fees set down by the MMFB and CFA for the provision of fire protection reports.

That year also saw the introduction of two Scholarships to Architectural Drafting Students – one at the RMIT and one at The Gordon Institute - \$300.00 each, after much discussion and deliberations with the management teams of both organisations to set guidelines and proper procedures in place for the selection process.

Meetings changed to the Royal Oak Hotel in Richmond in 1988, where somewhat better facilities were available – though still not the ultimate.

I presented the first scholarship to the RMIT on 21 October 1988 and the first to the Gordon Institute was presented in May 1989 – although we were not invited to that function.

Poor attendance at meetings was seen as an ongoing problem during this period, in spite of industry visits and other attempts to inspire members to attend.

We had a visit from the SA President at the 1988 AGM, and I went over there in September 1989 on a return visit, during which time the formation of The National Body was the topic of much discussion. They were all fired up and ready to go, but we were still coming to terms with a relatively small membership and even less members keen to be part of such an event.

The review of The Architect's Act took much of our time and effort in 1989 and 1990, especially Roger Daniel who was heavily involved in attending to same on all fronts.

In June 1990 the BDAQ came on stream thus making the formation of a National body somewhat more realistic.

I presented another scholarship at The Gordon Technical College in Geelong on 9 May 1990.

We were also invited to be represented on a Course Advisory Committee to review the curriculum of the Associate Diploma of Architectural Technology at the RMIT in that year. I am not sure who took up that position – and indeed if it was taken up.

Move to produce a regular Newsletter was also made late that year.

My term of office finished in July 1989.

1989-1991

contribution by Kevin Slater

BDAV Member Number 13; joined March 1983

Having been in my own design practice since 1969, I thought nothing of attending the inaugural formation meeting in Melbourne in November 1982 at which the Building Design Association was first proposed to give standing to Building Designers such as myself who worked largely in their own sole practices at that time.

The actual Inaugural Annual General Meeting was held on the 10th March 1983, and all members present were formally invited to join the Association and, upon receipt of their Membership Fees, would be duly accepted as members of the Association. Since that time I have proudly displayed my Registration Certificate No.13!

It was at the 7th Annual General Meeting of the Building Designers Association of Victoria Inc. held at the Smith Street Bar & Bistro, Fitzroy, on Thursday, 20th July 1989 that I was elected President to follow the leadership of past presidents, Bruce, Ron and Graeme; I had previously served two years as Vice President.

In reviewing past minutes and records, it was on the 9th November 1989 that there was a special meeting of the Executive Committee to discuss 'Review of the Architects Act' and its implications for all Building Designers.

On the 9th May 1990, I had the honor of representing the Association at the Award night of the Gordon Technical College, Geelong, and presenting the winner, Mr Greg McNeil with his BDAV Award being a cheque for \$150.00 being a means of promoting the Association and engendering close co-operation between the educational institutions offering drafting and building design and our Association.

In reviewing the past minutes, it was noted there were 32 members of the Association as at the 10th May 1990, in somewhat stark contrast to our present membership numbers!

The 8th Annual General Meeting was held on the 19th July 1990 at Clunes Ross House, 191 Royal Parade, Parkville at which my term as President continued.

It was at the above meeting that, after a period of four years in the role as Minute Secretary, my wife Denise relinquished her role due to her change of employment to Office Manager in a local business.

At the Executive Committee Meeting on the 14th November 1990, it was agreed by the Executive Committee members present – being Roger Daniel, Ray Watts, David Cooke, Bruce Pittard, Frank Masten and myself – that Eastwood Secretarial Service of Ringwood East be appointed to provide the professional secretarial needs of the BDAV.

In November 1990, I represented the Association at a Forum and prepared an Association Statement on a 'Discussion Paper on the use of Private Certification' which had been established by the National Committee on Certification.

At the same meeting I reported on moves by BDASA to form a National Body. A draft Constitution had been distributed by BDASA to other States and each State was to consider its position on this matter.

Like a lot of matters, considerable time elapsed between phases of the National Body evolving.

In April 1991, I had the privilege of representing Victoria at the inaugural meeting of the then States with Building Design Associations, namely South Australia, Victoria, Queensland and Western Australia, at which the Memorandum and Articles of Association were established and which led to the formal formation of the National Association.

Upon further reviewing past minutes, they indicate that, at a general meeting of members on the 12th December 1991 with 18 members attending, the guest speaker was Mr Howard Bartlett of the Urban Land Authority who spoke on the subject "Smart Block Design". This was probably the fore-runner of the latest ResCode 2000 promulgation's of the Building Control and Planning Divisions of Government!

As part of the expanding role of the National Body, I had the privilege of representing BDAV by invitation of and at the BDA Queensland in 1992 Annual Conference and Design Awards in Brisbane held on the 23rd and 24th May 1992.

This highlighted to me that, with a broad base and larger membership, BDAQ was able to successfully mount a Design Awards event which gave great promotion to the Association in that State and which was something lacking in Victoria, but could serve as an incentive to emulate.

Fellow membership classification was awarded to those members who had served in an Executive role for a period of ten years in 1994; I was elected a Fellow in 1995. This provided a great honor to those who had originally established the BDAV and who had diligently served in various Executive positions during their respective terms.

The incorporated company, Building Designers Association of Australia Ltd. was registered on the 20th February 1995; I having accepted the role as a Director of the company representing BDAV. The first meeting in person of the Directors of the BDAA Ltd was held in Sydney on Saturday, the 8th April 1995 attended by the Directors representing WA, SA, Vic, NSW and Qld. It was at this meeting that moves were made to foster a truly National Association by pairing States ie Victoria to help establish a BDA in Tasmania, BDASA to assist in the formation of Northern Territory; BDANSW already having a branch structure with one branch based in Canberra, ACT. The parameters for the initial National Design Award based on the model used by BDAWA were also set. The Awards to be held in Sydney, October 1995 in conjunction with the BDANSW Conference.

At the BDAA Meeting held on the 2nd and 3rd of December 1995, a unanimous decision was taken to appoint Mr Luke Solly as the Chief Executive Officer for BDAA. At this meeting, it was decided that it would be the policy of the BDAA that all Member Associations and individual members be known as Building Designers and not use any other terminology or description.

The first BDAV Design Awards were held on the 23rd August 1996 at the ANZ Pavilion, Victorian Arts Centre.

The category winners from our State Awards namely Robert McLauchlan for additions to residence at Donvale, Tanya Robertson of Taro Design for Best Interior and Graaph Design Pty Ltd. (Geoffrey Hoare, Principal) for Office Category were all successful in the National Awards, the first year in which Victoria had participated.

It was at the Annual General Meeting held on the 23rd October 1997 that, after a period of ten years serving on the Executive Committee, firstly as Vice President and then President, each for two year successive terms and since then for the past seven years as a Delegate and more latterly as Director on the National Body representing Victoria, I relinquished my active roles following my formal resignation as a Director at the Company Meeting in Sydney, October 1997 in order that I could concentrate more of my precious time to my own ever expanding business of now some 31 years!

I believe that, in meeting the challenge of the 90s, everyone associated with our profession and as members of our Association have been rewarded by recognition as Building Designers, achieved largely by the combined efforts of the various Past Presidents of the BDAV.

K Slater

1991-1993

contribution by David Cooke

BDAV Member Number 46; joined June 1988

I initially joined the BDAV in June 1988 and, after a short time as an Associate Member, I was elected to the Committee of Management in September 1989. After serving for two years as a committee member, I was elected as Vice President in September 1990 and served in this position for a year, until I became President of the Association in September 1991. I was President for two terms until September 1993. After this, I held the unelected position of Immediate past President for some years.

During my term as President, I recall the character of the BDAV and events as follows:

My initial impression of the BDAV was as a social group where designers met and exchanged ideas. Very few outside influences affected the Association, which, whilst having its own identity, was linked very closely with the BDASA from which it was conceived. Membership at this time was approximately 40 designers, who were all male and over 30 years old. Meetings were held in the function rooms of various inner city pubs and later at Clunies Ross House, which was home to a number of similar associations. The move to Clunies Ross House was the first attempt by the BDAV to be seen as a representative body rather than a social gathering. Initially, minutes of meetings were produced and forwarded to members after each meeting. These were a rather dry account of events. During my term, the Committee agreed to the introduction of the BDAV newsletter. As I recall, I edited it and wrote a number of articles, while other Committee members provided backup articles. Ray Watts was a great help and could always be counted on to provide an article or an update on Standards Association publications.

Prior to 1993, Professional Indemnity Insurance was available to BDAV members via the BDASA broker in Adelaide (Minets). During my term as President, the Committee negotiated the BDAV's own insurance and formed an alliance with Sedgwicks, who already provided P.I. Insurance to similar associations.

The major event to challenge Building Designers during my term of office was a review of the Architects Act in Victoria. This was instigated by the (then) Planning Minister, Evan Walker, himself a well-known architect. The review of the Act included the possibility of the restriction of certain documentation to registered Architects, and clearly threatened the scope of work conducted by Building Designers. Fortunately, Commonwealth trade Practices legislation had recently been introduced, and this served as our greatest defence against restriction of trade. The use of the term Architect and its derivatives was also included in the review of the Act, and this was of great concern to many Building Designers, since most at the time referred to themselves

as Architectural Draftsmen, and the Architects Board regularly sent infringement notices to any person who described themselves in this way. The BDAV made a detailed submission to the Government relating to the Architects Act and, in particular, to the possible restriction of trade and the use of the classification Architect. History shows that the BDAV was successful on the issue of the restriction of trade, but not on the use of the term Architect. This was the first time that the Association had made representations to Government and it provided the beginning of acknowledgement of the Association as a recognised body representing Building Designers.

During this time the BDAV had its first formal contact with the RAIA. Rob McLauchlan - who was Vice President at that time - and myself had a meeting with the President of the RAIA at their Melbourne headquarters. I recall that the RAIA had never heard of Building Designers, let alone an Association. Soon after this meeting, the RAIA suggested a form of alliance where we would be included in a limited category of membership of their Association. Our feeling was that they would rather have us under their control than going our own way, and so naturally we decline their invitation. Soon after, they formed their own drafting group within the RAIA. The review of the Architects Act had stirred up Victorian Building Designers and it was apparent that membership was slowly increasing. Application for membership had been assessed by the Executive Committee up to this point, but it had many other pressing tasks. Colin Mellett and Peter Condos had been Committee members and they agreed to help with assessments. As I recall, Frank Masten and Ray Watts helped out, and without realising it, the Membership Assessment Committee was formed.

The BDAV's more prominent profile came to the attention of Alex Nu, Head of Architectural Drafting at RMIT. Alex had lectured to many BDAV members and was interested in the Association. He invited me to join the Assessment Panel to review the TAFE Architectural Drafting Course. This was a notable event, since it gave the BDAV a voice in shaping the course which the majority of its members studied.

On the national front, the emergence of the BDAQ developed quickly and they had a membership double the BDAV within a year of formation. We kept in close contact with them, and I attended their first conference whilst on holidays in Queensland. They also organised a study tour of the United States and some BDAV members went on this trip.

I have greatly enjoyed my time with the BDAV and feel that, during my term in office, much was achieved by the Association. I am grateful to those committee members who worked with me, and those who have held office since then. I have formed many strong friendships through the Association.

D Cooke

1993-1997

contribution by Robert McLauchlan

BDAV Member Number 61; joined July 1991

1993-1994

Executive meetings were held in the premises of Executive members.

General meetings were held at Clunies Ross House and were usually followed by a meal.

Membership Categories were changed to incorporate the entry standard of Registered Building Practitioners in the form of Category C Membership. Categories A & B equated to Associate and Member Categories respectively. Corporate, Student and Honorary Categories were added.

During late 1993, BDAV lobbied heavily to promote its presence and industry status in the face of the pending Victorian Building Act and requirement for registration of practitioners under the Building Practitioners Board. The Association lobbied heavily to obtain representation on the Board and was rewarded when Roger Daniel's nomination was accepted.

Sedgwick Insurance became the recommended provider of Professional Indemnity Insurance to members.

The Membership expanded rapidly during the first few months after Registration, growing from approximately 45 to well over 100.

1994-1995

Unquestionably the most significant year of change since the formation of the BDAV.

- Executive meetings were held in the offices of Executive Members.
- General Meetings were held at the Bruce County Motor Inn in Glen Waverley, and at Drummond Street Carlton, members enjoyed finger food refreshments.
- Workload of the Executive increased markedly and the decision was taken to investigate the appointment of a CEO during late 1994.
- The Executive advertised widely seeking expressions of interest for an Executive Officer to handle the administrative affairs of the Associations. Assignments Australasia Pty Ltd were subsequently appointed, providing all the services the Association needed and more. A true leap in professionalism commenced with their appointment in November 1994.
- Considerable energy was expended implementing the new management structure, however, during this year other initiatives included:
 - The production and sale of BDAV Site Signs.
 - BDAV submission to the new State Planning Code Draft "Victorian Design Guide for Medium Density Housing", which became "The Good Design Guide".
 - Development of recommended Scale of Fees and Charges.
 - Volume One Edition 1 of *BDAV News*, the monthly newsletter of the Building Designers Association of Victoria, was published in December 1994. After advertising for the most suitable name the Committee

- chose to stay with the original 'temporary' name.
- Design and production of BDAV Presentation Folders.

1995-1996

Budget Total - \$80K

Membership Total 210 including Tasmania.

- Executive meetings held in offices of the Executive.
- General meetings were held in the office of Assignments Australasia at Drummond Street Carlton, usually attended by 40-60 members.
- The Inaugural BDAV Design Awards were held, with outstanding success with the Presentation Dinner Dance at Ripponlea, and attended by the (then) Minister for Planning, the Hon. Robert Maclellan.
- A combined Victoria/Tasmania Branch commenced with small but active Groups based in Launceston and Hobart.
- The first Regional Group was formed in Bendigo.
- BDAV entered into its first association with Interbuild where we manned a stand with examples of works from the design awards and offered promotional brochures to potential members and took enquiries from potential clients.
- Industry and Government representation was established with
 - Department of Planning and Heritage
 - Urban Land Authority
 - TAFE National Curriculum Advisory Panel.
- The first *Tools of the Trade* night was held where members displayed and discussed a range of architectural software packages.
- The first Building Designers Diary was produced, with a list of Councils and Contacts included.

1996-1997

- Committee Meetings and General meetings were held in the offices of Assignments Australasia at Drummond Street, Carlton.
- BDAV sponsored the Outstanding Student at the Gordon Institute of TAFE with a presentation at their Graduation Ceremony.
- Membership categories were amended to Member, Associate, Fellow, Life, Honorary, Corporate Student. Class A & B Members automatically to become Associate and Class C and to become 'Members'.
- The Professional Development Program was introduced on 1 November 1996. Initially this was a voluntary program which required a minimum number of points to be accrued over a three-year period. Points were allocated for actual hours spent actively participating in seminars and courses. Details to be recorded in a Log Book maintained by members, to be audited annually by the BDAV. Members were able to progress to higher levels of membership classifications upon satisfactorily completing the PD Program requirements.
- BDAV again produced their Building Designer Diary.
- Annual Dinner and Design Awards Presentation was held at the ANZ Pavilion, attended by the Minister for Planning, the Hon. Robert Maclellan.
- Roger Daniel was elected to the Building Practitioners Board for his second term.

R McLauchlan

1997-1999

contribution by Sean Hamilton

BDAV Member Number 71; joined August 1993

Main Goals as President:

- To focus BDAV on delivering our Members needs.
- To promote the BDAV as a credible Association.
- To articulate our Members' views at Local and State Government.
- To elevate the status of the Student and Graduate.
- To strengthen the Association's Financial sustainability.
- To reach out to the membership from the Executive with a home and a face charged with the management of the BDAV.

Members Needs:

- This was achieved by steering the continuing Professional Development Programme to focus on issues and topics contemporary to our members needs.
- Promote and encourage Members to grasp the new and innovative technology emerging in the Industry, ie, Tools of the Trade Seminar initiative, and Interbuild participation.

BDAV Promotion:

I accepted every opportunity to represent the BDAV and articulate the members' professional views on contemporary issues. This was achieved with a rigorous two year schedule of participation on Local and State Government Committees and Sub Committees, peak body industry committees and seminars, Government and TAFE training & education committees and conferences, and national issues related to our State Members at the BDAA.

Students & Graduates:

I accepted regular invitations from TAFE and tertiary institutions to talk to classes of students from an industry perspective and underline the importance of their academic achievement relative to the industry. I encouraged the industry to invest the future of our industry by articulating the needs of the student and graduate to manufacturers and suppliers and members. I also encouraged the members to accept a role as continuing mentor and educator to shape and cultivate the potential of the graduate.

BDAV Financial Sustainability:

This was achieved by strengthening the BDAV's industry sponsorship and participation in CPD seminars and meeting. A Government grant was sought (and achieved) through EcoRecycle Victoria to prepare a public document and training manual drawn from member's professional expertise specific to our industry – "*Designing in Waste Minimisation*". We continued promotion of the BDAV through the TAFE Colleges.

A Name and a Face to the BDAV Management:

I initiated the *President's Palaver* column in the monthly newsletter, *BDAV News*. The main aim of this initiative was to reach out to the membership with a casual and informal opinion from the Association's President, to those who, in my term, I would not have the opportunity to meet. This also elevated the profile of the President and the BDAV and, in the course of meeting many people in Government, industry and education, I found myself (and my views) and the BDAV already known to those who I was yet to be introduced to.

Term Summary – Main Achievements:

- BDAV News : *President's Palaver* column
- BDAT attained self autonomy
- First Government Grant – Eco Recycle, Waste Minimisation
- CPD
 - Calendar schedule, contemporary issues and topics
 - Tool of the Trade Initiative
 - Interbuild Participation
- Students
 - Design Awards Cat' Educational Trust Fund
 - Implementation of National Curriculum
 - Industry Representation to National Curriculum
- BDAV new Promotional/Member marketing brochure
- Government and Industry Committees:
 - Department of Infrastructure
 - Planning systems management & reform peak body
 - Training, education & communication
 - Demolition & Heritage
 - Industry
 - AIBS Conference : Disability Discrimination Act
 - MBAV : Tendering and Infrastructure
 - Education
 - TAFE – National Curriculum Industry Representative
 - National
 - BDAA : became Victorian Member Representative
 - Initiative in addition to State Directors
 - Competency Standards discussed
- Good Design Guide Amendment – Site Analysis
- Melbourne Water – New Floor Levels
- BCA
 - Disability Discrimination Act & Regulation Amendments
- BDAV & PDDG – initiate discussions for closer ties and possible amalgamation
- BDAV Management – initiate management handbook
- Initiated committee management portfolios
- BDAV Specification : established a sub-committee to investigate association specification for Members.

S Hamilton
